

SDM630MB

MID APPROVED 100 AMP DIRECT CONNECTED THREE PHASE DIGITAL MULTIFUNCTION METER WITH MBUS & PULSED OUTPUT

Data Sheet

2018 v2.0

SDM630-Series
DIN Rail Multifunction Power Meter

Data Sheet

2018 v2.0

SDM630-Series
DIN Rail Multifunction Power Meter
- 100A Direct Connected
(MID Certified)

- SDM630-Modbus (Modbus RTU & Pulsed Output)
- SDM630-MBus (Mbus & Pulsed Output)
- SDM630-MT (Multi-Tariff, Modbus RTU & Pulsed Output)
- SDM630-Pulse (Pulsed Output Only)
- MID B&D Certified by SGS
- Certified for Single & Three Phase
- Certified for Import / Export kWh



SDM630 Series Multifunction Power Meter

The SDM630 is a new generation modern design power monitor that will measure and display electrical power quality parameters. It has been engineered to cover most applications (Single Phase and Three Phase networks). There are also 4 models available depending on the output required, this ranges from a Pulsed Output (SDM630- Pulse), Modbus RTU (SM630-Modbus), MBus (SDM630-MBus), and Multi-Tariff (SDM630-MT).

As the demand for MID certified meters has increased, we have obtained annex B and D of the EC Directive 2004/22/EC. This power meter has been tested and certified for single or three phase networks and import and export active energy (kWh).

The SDM630 is produced to the highest quality and utilizes the latest microprocessor and technology. It has a blue backlit display and 16 different measuring parameters. This meter supports a maximum 100A Direct connection. Available with built in pulsed outputs and RS485 Modbus RTU it is fully compatible for integration with BMS and remote monitoring systems.

Parameters

- Phase to Neutral Voltage (V)
- Phase Current (A)
- Voltage Total Harmonic Distortion (U%THD)
- Current Total Harmonic Distortion (I%THD)
- Frequency (Hz)
- Power Factor (PF)
- Current Max Demand (MD A)
- Power Max Demand (MD kW)
- Active Power (kW)
- Reactive Power (kVAR)
- Apparent Power (kVA)
- Import Active Energy (kWh)
- Export Active Energy (kWh)
- Total Active Energy (kWh)
- Import Reactive Energy (kVARh)
- Export Reactive Energy (kVARh)
- Total Reactive Energy (kVARh)

Specifications

Measured Parameters

The unit can monitor and display the following parameters of a Single Phase Two Wire (1P2W), Three Phase Three Wire (3P3W) or Three Phase Four Wire (3P4W) system.

Voltage and Current

- Phase to Neutral Voltages 100-289V AC (not for 3P3W supplies).
- Phase to Phase Voltages 173-500V AC (3 Phase supplies only).
- Percentage Total Voltage Harmonic Distortion (U% THD) for each Phase to N (not for 3P3W supplies).
- Percentage Voltage Total Harmonic Distortion (U% THD) between Phases (3 Phase supplies only).
- Percentage Current Total Harmonic Distortion (I% THD) for each Phase.

Power factor and Frequency and Max. Demand

- Frequency in Hz
- Instantaneous power:
- Power 0-3600 MW
- Reactive Power 0-3600 MVar
- Volt-Amps 0-3600 MVA
- Maximum Demand Power since last reset
- Power factor
- Maximum neutral Demand Current, since the last reset (for Three Phase supplies only)

Energy Measurements

Imported/Exported active energy	0 to 9999999.9 kWh
Imported/Exported reactive energy	0 to 9999999.9 kVarh
Total active energy	0 to 9999999.9 kWh
Total reactive energy	0 to 9999999.9 kVarh

Measured Inputs

Voltage Inputs through 4-way fixed connector with 25mm² stranded wire capacity. Single Phase Two Wire(1P2W), Three Phase Three Wire(3P3W) or Three Phase Four Wire (3P4W) unbalanced. Line frequency measured from L1 Voltage or L3 Voltage.

Nominal Voltage Input	100-289V AC (Ph+N) or 173-500V AC (Ph+Ph)
Max Continuous Voltage	120% of Nominal
Nominal Input Current	0.5-10(100)A AC
Max Continuous Current	120% of Nominal
Frequency	50Hz ±10%

Accuracy

Voltage	0.5% of range maximum
Current	0.5% of nominal
Frequency	0.2% of mid-frequency
Power Factor	1% of unity (0.01)
Active Power (W)	±1% of range maximum
Reactive Power (VAr)	±1% of range maximum
Apparent Power (VA)	±1% of range maximum
Active Energy (Wh)	Class 1 IEC 62053-21
ReactiveEnergy (VARh)	±1% of range maximum
Total Harmonic Distortion	1% up to 31st harmonic
Response time to step Input	1s, typical, to >99% of final reading, at 50 Hz.

Auxiliary Supply

This unit does not require a separate auxiliary supply as it is self-powered from the Voltage inputs.

Interfaces for External Monitoring

Three interfaces are provided:

- RS485 communication channel that can be programmed for Modbus RTU protocol
- Relay output indicating real-time measured energy (configurable)
- Pulse output 3200IMP/kWh (not configurable)

The Modbus configuration (baud rate etc.) and the pulse relay output assignments (kW/kVAh, Import/export etc.) are configured through the set-up screens.

SDM630 -Pulse (Pulsed Output Only)

Opto-coupler with potential free SPST-NO Contact (Contact rating - Voltage: 5-27V DC, Current: Imin 2mA and Imax 27mA DC). The pulse output can be set to generate pulses to represent kWh or kVAh.

Rate can be set to generate 1 pulse per:

0.01 = 10 Wh/VAh

0.1 = 100 Wh/VAh

1 = 1 kWh/kVAh

10 = 10 kWh/kVAh

100 = 100 kWh/kVAh

Pulse width 200/100/60 ms.

SDM630 - Modbus (RS485 Output for Modbus RTU & Pulsed Output)

For Modbus RTU, the following RS485 communication parameters can be configured from the set-up menu:

Baud Rate: 2400, 4800, 9600, 19200, 38400

Parity: None (default) / Odd / Even

Stop Bits: 1 or 2

RS485 Network Address: 3 Digit Number - 001 to 247

Modbus* Word order Hi/Lo byte order is set automatically to normal or reverse. It cannot be configured from the set-up menu.

SDM630MCT-MBus (MBus & Pulsed Output)

The meter provides a M-bus port for remote communication. M-bus protocol is applied.

Baud Rate 300 / 600 / 1200 / 2400 / 4800 / 9600

Parity NONE / EVEN / ODD

Stop Bits 1 or 2

Primary Address 1 - 250

Secondary Address 00 00 00 01 to 99 99 99 99

SDM630 - MT (Multi-Tariff, RS485 Output for Modbus RTU & Pulsed Output)

For Modbus RTU, the following RS485 communication parameters can be configured from the set-up menu:

Baud Rate: 2400, 4800, 9600, 19200, 38400

Parity: None (default) / Odd / Even

Stop Bits: 1 or 2

RS485 Network Address: 3 Digit Number - 001 to 247

Modbus* Word order Hi/Lo byte order is set automatically to normal or reverse. It cannot be configured from the set-up menu
Multi Tariff.

Reference Conditions of Influence Quantities

Influence Quantities are variables that affect measurement errors to a minor degree. Accuracy is verified under nominal value (within the specified tolerance) of these conditions.

Ambient temperature	23°C ±1°C
Input waveform	50 or 60Hz ±2%
Input waveform	Sinusoidal (distortion factor < 0.005)
Auxiliary supply voltage	Nominal ±1%
Auxiliary supply frequency	Nominal ±1%
Auxiliary supply waveform (if AC)	Sinusoidal (distortion factor < 0.05)
Magnetic field of external origin	Terrestrial flux

Environment

Operating temperature	-25°C to +55°C*
Storage temperature	-40°C to +70°C*
Relative humidity	0 to 95%, non-condensing
Altitude	Up to 3000m
Warm up time	1 minute
Vibration	10Hz to 50Hz, IEC 60068-2-6, 2g
Shock	30g in 3 planes

*Maximum operating and storage temperatures are in the context of typical daily and seasonal variation.

Mechanics

DIN rail dimensions	72mm x 100mm (WxH) per DIN 43880
Mounting	DIN rail (DIN 43880)
Sealing	IP51 Indoor
Material	Self-extinguishing UL 94 V-0

Installation

Wiring diagram

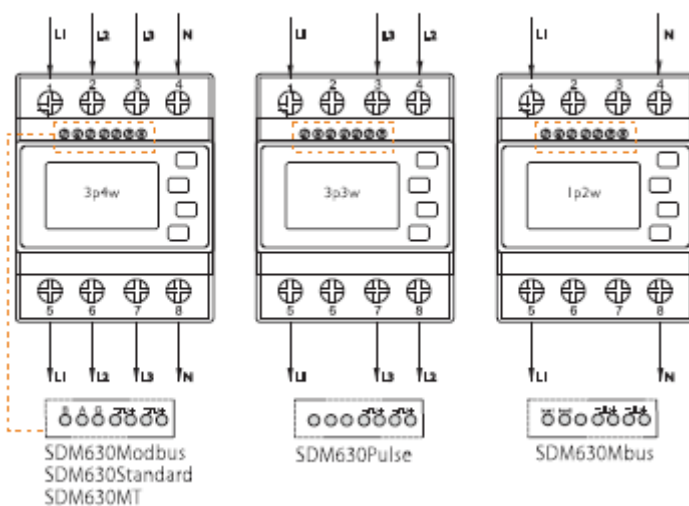

Dimensions

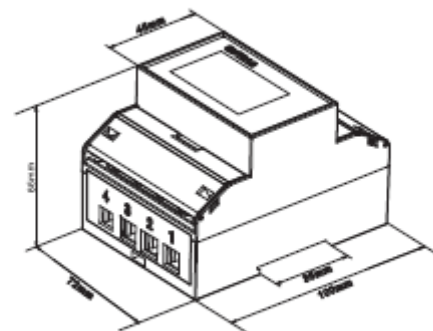

Height 100mm
Width 72mm
Depth 66mm