

SDM230MBUS

100 AMP SINGLE PHASE DIN MOUNTED 2 MODULE METER WITH MBUS

Data Sheet

DIN Rail Multifunction Power Meter (MID Certified)

- MID B+D Certified
- Class B (kWh) EC Directive 2004/22/EC
- Certificate Number 0120/SGS0198
- Multifunction 100A Direct Connected
- Built In Pulsed & MBus Outputs



SDM230-MBus Multifunction Power Meter

The SDM230-MBus is a new generation modern design power monitor that will measure and display electrical power quality parameters. It has been engineered to cover most applications (Single Phase networks / Built in Pulse and MBus / Import and Export kWh), replacing the need for several different models of this power meter.

As the demand for MID certified meters has increased, we have obtained annex B and D of the EC Directive 2004/22/EC. This power meter has been tested and certified for single phase networks and import and export active energy (kWh).

The SDM230-MBus is produced to the highest quality and utilizes the latest microprocessor and technology. It has a blue backlit display and 16 different measuring parameters. With built in pulsed outputs and MBus it is fully compatible for integration with BMS and remote monitoring systems.

Parameters

- Phase to Neutral Voltage (V)
- Phase Current (A)
- Frequency (Hz)
- Power Factor (PF)
- Power Max Demand (MD kW)
- Active Power (kW)
- Reactive Power (kVAr)
- Apparent Power (kVA)
- Import Active Energy (kWh)
- Export Active Energy (kWh)
- Total Active Energy (kWh)
- Import Reactive Energy (kVArh)
- Export Reactive Energy (kVArh)
- Total Reactive Energy (kVArh)

Specifications

Measured Parameters

The unit can monitor and display the following parameters of a single phase two wire (1p2w) system.

Voltage and Current

- Phase to neutral voltages 176 to 276V a.c.
- I_{min}-I_{ref} (Max) 0.5-10(100A)

This meter is certified and tested at class 1 (Accurate to within ±1%). If the meter has a load smaller than the I_{min} (minimum current) we cannot guarantee class 1 accuracy.

Power factor and Frequency and Max. Demand

- Frequency in Hz
- Instantaneous power:
- Power 0 to 3600 MW
- Reactive power 0 to 3600 MVAR
- Volt-amps 0 to 3600 MVA
- Maximum demanded power since last Demand reset Power factor

Energy Measurements

Imported/Exported active energy	0 to 99999.99 kWh
Imported/Exported reactive energy	0 to 99999.99 kWh
Total active energy	0 to 99999.99 kWh
Total reactive energy	0 to 99999.99 kWh

Measured Inputs

Voltage inputs through 3-way fixed connector with 19mm² maximum terminal wire.

Nominal Voltage Input	(Ph+N) 176 to 276V
Max Continuous Voltage	120% of nominal
Nominal Input Current	0.5-10(100A)
Max Continuous Current	120% of nominal
Nominal Input Current Burden	0.5VA
Frequency	50Hz(±10%)

Accuracy

Voltage	0.5% of range maximum
Current	0.5% of nominal
Frequency	0.2% of mid-frequency
Power factor	1% of unity (0.01)
Active power (W)	±1% of range maximum
Reactive power (VAR)	±1% of range maximum
Apparent power (VA)	±1% of range maximum
Active energy (Wh)	Class 1 IEC 62053-21
Reactive energy (VARh)	±1% of range maximum

Interfaces for External Monitoring

Two interfaces are provided:

- MBus
- Relay output indicating real-time measured energy.(configurable)

Pulse Output

The meter provides two pulsed outputs, both pulsed outputs are passive type. The first pulsed output is configurable. The pulsed output can be set to read total / Import / export/ kWh / kvarh. The pulse constant can be set to generate 1 pulse per: 0.001 (default) /0.01/0.1/1kWh/kvarh. The second pulsed output is non-configurable. It is fixed to read total kWh.

Rate can be set to generate 1 pulse per:

0.001 = 1 Wh/kvarh (default)

0.01 = 10 Wh/kvarh

0.1 = 100 Wh/kvarh

1 = 1 kWh/kvarh

Pulse width 200/100/60 ms.

M-Bus

The meter provides a M-bus port for remote communication. M-bus protocol is applied.

Baud rate 300, 2400, 4800, 9600.

Reference Conditions of Influence Quantities

Influence Quantities are variables that affect measurement errors to a minor degree. Accuracy is verified under nominal value (within the specified tolerance) of these conditions.

Ambient temperature	23°C ±1°C
Input waveform	50Hz ±2%
Input waveform	Sinusoidal (distortion factor < 0.005)
Auxiliary supply voltage	Nominal ±1%
Auxiliary supply frequency	Nominal ±1%
Auxiliary supply waveform (if AC)	Sinusoidal (distortion factor < 0.05)
Magnetic field of external origin	Terrestrial flux

Environment

Operating temperature	-25°C to +55°C*
Storage temperature	-40°C to +70°C*
Relative humidity	0 to 95%, non-condensing
Altitude	Up to 3000m
Warm up time	1 minute
Vibration	10Hz to 50Hz, IEC 60068-2-6, 2g
Shock	30g in 3 planes

*Maximum operating and storage temperatures are in the context of typical daily and seasonal variation.

Mechanics

DIN rail dimensions	mm x mm (WxH) per DIN 43880
Mounting	DIN rail (DIN 43880)
Sealing	IP51 Indoor
Material	Self-extinguishing UL 94 V-0

Dimensions

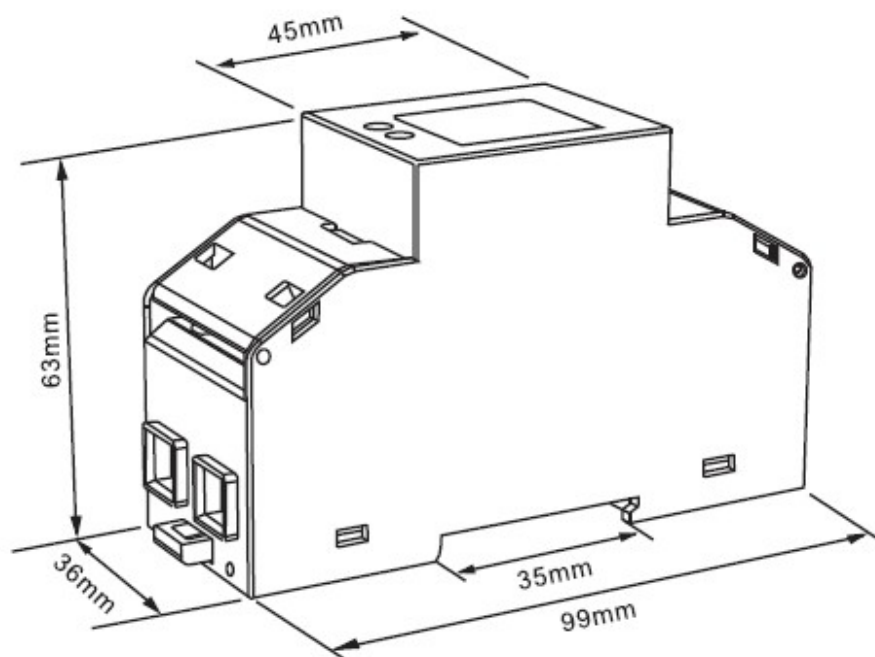

Installation

